

REVISION RECORD				
SYM	DESCRIPTION	BY	DATE	APPD

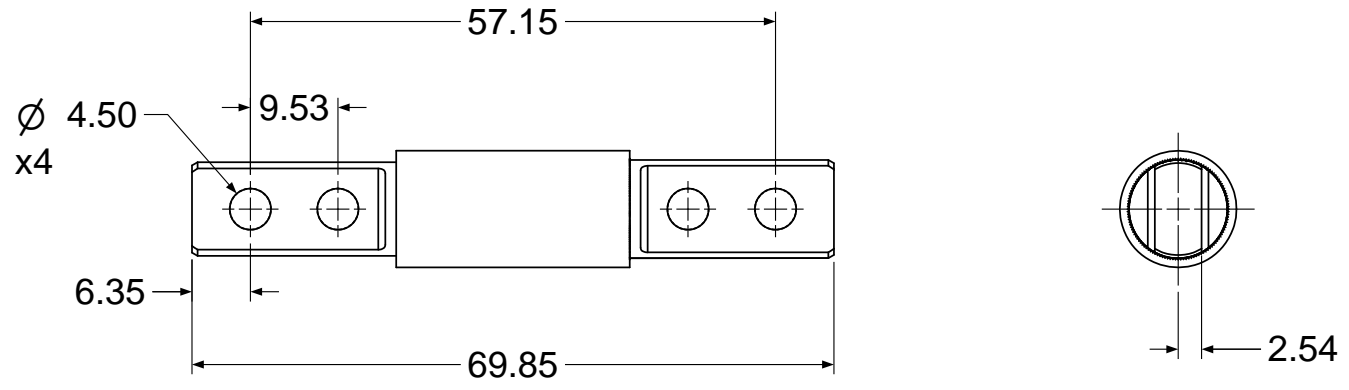
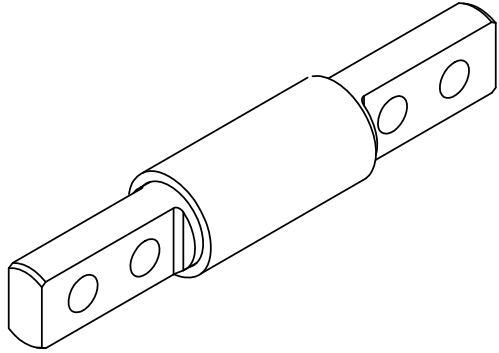

NOTES:

1) CW TORQUE = CCW TORQUE = 3.0 ~ 6.0 IN.LB.

USED ON	SOLID	REV	TOLERANCES		ENGLISH / METRIC Shinelet Enterprise			
			ENGLISH	METRIC				
NEXT ASSY			.XX .015 IN .XXX .005 IN	.X ±.3 MM .XX ±.13 MM .XXX ±.05 MM	DRAWN BY	DATE	MATERIAL	
QUANTITY							TITLE	
PER ASSY, PCS	1		ANGLES 7.57		CHECKED BY	DATE	C-601	
TOTAL, PCS	1		SURFACE 63				SIZE	REV
							C	0.0
					SCALE		1:1	SHEET 1 OF 1